



# Roller and Skate Wheel Conveyor

With Alluserv you are not just buying a product. You are receiving our team's service commitment to get the most value from your investment in our products. We will provide you with:

- A team of knowledgeable experts with over 100 years of combined experience to help you understand and receive the most from your product throughout its service life
- Detailed instructions and specification on cleaning and application to best maintain your equipment
- A national service network and service manuals for our extensive product offering.

## Model Numbers:

**RC10, RC12, RC14, RC16, RC18, RC20, SWC10, SWC12, SWC14, SWC16, SWC18, SWC20**

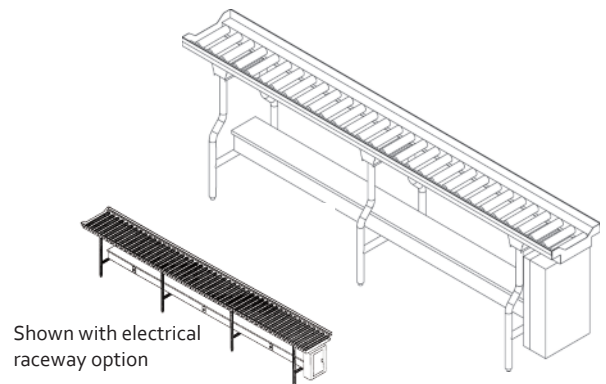

## ROLLER AND SKATE WHEEL CONVEYOR

### APPLICATION

The straight-line roller and skate wheel conveyors are designed for tray make-up operations. These conveyors will help streamline tray assembly for any healthcare operation. Mobile or stationary, these units are designed for easy cleaning and long life. Since these units are built to customer specification, some units may not be available in mobile configuration. Please consult factory.

### CONSTRUCTION

The open pan conveyor body is constructed with 14-gauge 304 stainless steel. The conveyor is supported by 1 5/8" (4cm) O.D. 16-gauge stainless steel tubular legs, which are welded to 14-gauge channels. These channels are then welded directly to conveyor frame.

Skate wheel assemblies are 2" (5cm) diameter nylon wheels with low friction bushing for free movement. Wheels secured to frame with stainless steel bolts and stainless steel self-locking nuts. Wheels spaced on 3" (8cm) - 4" (10cm) centers removable for cleaning to ensure positive contact between tray and roller. Wheels are removable for easy cleaning.

Rollers are 2" (5cm) O.D. grey PVC tubing with stainless steel ball bearings to ensure easy, reliable movement. Rollers are mounted on stainless steel, hex spring loaded shafts for easy removal during cleaning and replacement. The Roller conveyor will handle compartmental or divided trays as well as flat bottom trays.

These conveyors come standard with stainless steel bullet feet which allows for adjustable height. For both type conveyors, tray size must be known when unit is ordered to provide proper size cross member and end plates to accommodate tray.

# Roller and Skate Wheel Conveyor

## Options

- Electric Raceways – All units can be equipped with electric raceways for your electrical convenience.
- Outlets – Allows you to plug in all support equipment. No more drop cords. Single or three phase outlets are available in either straight blade or twist lock.
- Field Joint – Allows longer conveyors to be shipped and maneuvered to location in smaller sections.
- Movable Over Shelf – This option gives extra surface area and easy access for dietary meal kits and other tray requirements.
- Casters – These conveyors come standard with adjustable bullet feet. Casters can be added if electrical loads permit.
- Removable Sections - Allows sections to be placed directly into dishwasher for easy cleaning.
- Cord & Plug – Conveyors are constructed for hard wiring as standard, requiring electrical service at location. Ground receptacle required for this option. This option is available on any unit with electric amp load of 100 or less.
- Stainless Steel Rollers

## Warranty

- Two years parts and one year labor

## DIMENSIONS

MODEL	A DIM	WIDTH	CASE WEIGHT
RC10	10 ft.	Tray size plus 1/2 inch	200 lbs
RC12	12 ft.	Tray size plus 1/2 inch	240 lbs
RC14	14 ft.	Tray size plus 1/2 inch	280 lb.
RC16	16 ft.	Tray size plus 1/2 inch	320 lbs
RC18	18 ft.	Tray size plus 1/2 inch	360 lbs
RC20	20 ft.	Tray size plus 1/2 inch	400 lbs

MODEL	A DIM	WIDTH	CASE WEIGHT
SWC10	10 ft.	Tray size plus 1/2 inch	200 lbs
SWC12	12 ft.	Tray size plus 1/2 inch	240 lbs
SWC14	14 ft.	Tray size plus 1/2 inch	280 lb.
SWC16	16 ft.	Tray size plus 1/2 inch	320 lbs
SWC18	18 ft.	Tray size plus 1/2 inch	360 lbs
SWC20	20 ft.	Tray size plus 1/2 inch	400 lbs

